

**CO-ORDINATED SCIENCES**

**0654/53**

Paper 5 Practical Test

**October/November 2016**

**CONFIDENTIAL INSTRUCTIONS**

**Great care should be taken to ensure that any confidential information given does not reach the candidates either directly or indirectly.**

**The Supervisor's attention is drawn to the form on page 8 which must be completed and returned with the scripts.**

If you have any problems or queries regarding these Instructions, please contact CIE

by e-mail: info@cie.org.uk

by phone: +44 1223 553554

by fax: +44 1223 553558

stating the nature of the query and the syllabus number quoted above.

This document consists of **7** printed pages and **1** blank page.

## Instructions for preparing apparatus

These instructions detail the apparatus, reagents and specimens required by each candidate for each experiment in this paper. A summary of the questions that will be presented to the candidates is included, where appropriate, to allow the teacher to test the apparatus appropriately. **No access is permitted to the Question Paper in advance of the examination session.**

It is assumed that the ordinary apparatus of a science laboratory will be available, including a supply of purified water (distilled or deionised).

If arrangements are made for different sessions for different groups of candidates, care must be taken to ensure that the different groups of candidates are effectively isolated so that **no information passes between them.**

**All specimens should carry only the code letters and numbers as indicated and their identity should not be revealed to the candidates.**

Supervisors should ensure that all specimens have the correct identity attached to the specimen and that these are **not** removed during the examination.

If a candidate breaks any of the apparatus, or loses any of the material supplied, the matter should be rectified and a note made in the Supervisor's Report.

Supervisors are advised to remind candidates that **all** substances in the examination should be treated with caution. Only those tests described in the Question Paper should be attempted. Pipette fillers and safety goggles should be used where necessary.

In accordance with COSHH (Control of Substances Hazardous to Health) Regulations, operative in the UK, a hazard appraisal of the examination has been carried out.

The following codes are used where relevant.

**C** = corrosive

**MH** = moderate hazard

**HH** = health hazard

**T** = acutely toxic

**F** = flammable

**O** = oxidising

**N** = hazardous to the aquatic environment

The attention of Centres is drawn to any local regulations relating to safety, first-aid and disposal of chemicals.

'Hazard Data Sheets', relating to materials used in this examination, should be available from your chemical supplier.

The Supervisor should make sure the Supervisor's Report is fully completed and a copy is enclosed with each packet of scripts.

Centres are reminded that they are **not** permitted to open the Question Paper envelopes before the examination. Centres are also referred to the Handbook for Centres, the Security of Question Papers and Examination Materials section, and the Practical Examinations in Science Subjects section.

If there are difficulties with any aspect of setting up this practical examination that the Centre is not able to resolve, it is essential for Centres to contact the Product Manager as soon as possible by e-mail to [info@cie.org.uk](mailto:info@cie.org.uk), by phone to +44 1223 553554 or by fax to +44 1223 553558.

**Question 1**

Each candidate will require:

- (i) rounded teaspoon of soft cream cheese (full fat or low fat) in a small beaker
- (ii) a quarter of an apple with the core removed but not peeled
- (iii) white tile
- (iv) cutlery knife (not a kitchen knife or scalpel)
- (v) distilled water
- (vi) stirring rod
- (vii) dropping bottle of Benedict's solution labelled **Benedict's solution** containing at least 10 cm<sup>3</sup>
- [N] (viii) dropping bottle of iodine solution labelled **iodine solution** containing at least 10 cm<sup>3</sup>
- [C] (ix) dropping bottle of biuret solution labelled **biuret solution** containing at least 10 cm<sup>3</sup>
- (x) 6 test-tubes 125 × 25 mm and a means of holding them
- (xi) access to a water bath of 85 °C
- (xii) test-tube rack
- (xiii) marker pen, suitable for labelling glass.

**Question 2**

Each candidate will require:

(i) at least 60 marble chips (2–4 mm) of approximately the same size labelled **marble chips**

(ii) approximately 60cm<sup>3</sup> 2.0 mol dm<sup>-3</sup> hydrochloric acid labelled **H**

**[MH]**(iii) approximately 60cm<sup>3</sup> limewater labelled **limewater**

(iv) test-tube (125mm × 15mm) with mark showing one third full and labelled **J** and means to rinse it

(v) test-tube (125mm × 15mm) with mark showing one third full and labelled **K** and means to rinse it

(vi) delivery tube with bung to fit test-tube **K**

(vii) stopwatch suitable for measuring to the nearest second

(viii) 25cm<sup>3</sup> measuring cylinder

(ix) 10cm<sup>3</sup> measuring cylinder

(x) small beaker

(xi) small container labelled **used chips**

(xii) stirring rod

(xiii) supply of water (if it is more convenient to supply this in a bottle then 250cm<sup>3</sup> would be appropriate and it should be labelled **water**).

### Question 3

Each candidate will require:

- (i) power source of approximately 1.5 – 2V. Where candidates are supplied with a power source with a variable output voltage, the voltage setting should be set by the Supervisor and fixed (e.g. taped)
- (ii) voltmeter capable of measuring the supply voltage with a minimum resolution of 0.1 V
- (iii) ammeter capable of measuring currents up to 1 A with a minimum resolution of 0.05 A
- (iv) three resistors of nominal value of  $5\ \Omega$  (e.g.  $4.7\ \Omega$ ) with a power rating of 2W (see notes 2 and 3)
- (v) switch – this can be an integral part of the power supply
- (vi) sufficient connecting leads to set up the circuit shown in Fig. 3.1, plus two additional leads.

### Notes

1. The circuit is to be set up for candidates as shown in Fig. 3.1 with points **X** and **Y** labelled and with the additional leads and the voltmeter within easy reach.

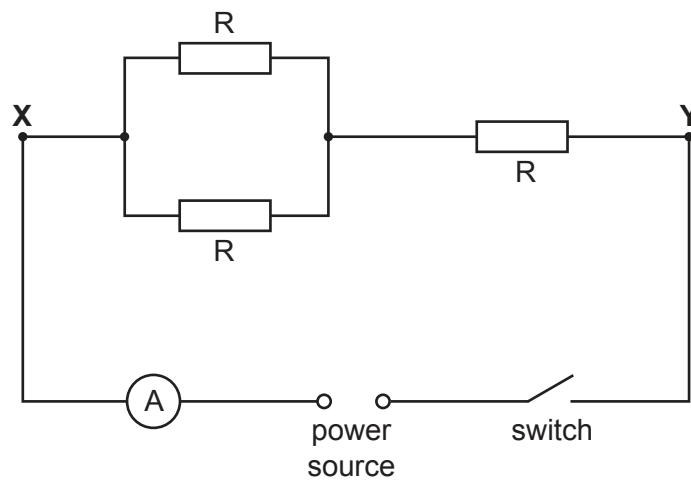

**Fig. 3.1**

2. The resistors must all have suitable terminals so that candidates can easily and quickly connect the voltmeter. Candidates will also be required to rearrange the resistors.
3. The resistors should be labelled R and positioned as shown in Fig. 3.1.

### Action at Changeover

Reconnect the resistors so that the circuit is as shown in Fig. 3.1. Do not connect the voltmeter.

Spare materials and equipment should be available and can be provided without penalty. **Candidates should be made aware of this.**

*Information required from the Supervisor:*

**The Supervisor is asked to carry out the experiments and to enter the results on a spare copy of the examination paper, clearly marked 'Supervisor's Results' and showing the Centre number. This should be done, out of sight of the candidates, using the same solutions, reagents, specimens and apparatus as the candidates.**

**A copy of the 'Supervisor's Results' should be returned with each packet of scripts. Failure to do so may cause the candidates to be penalised.**



**This form must be completed and returned in the envelope with the scripts together with the seating plan and the Supervisor's Results as mentioned on page 6.**

**October/November 2016**

*General*

The Supervisor is invited to give details of any difficulties experienced by particular candidates giving their names and candidate numbers. These should include reference to:

- (a) difficulties due to faulty apparatus;
- (b) accidents to apparatus or materials;
- (c) physical handicaps, e.g. short sight, colour blindness;
- (d) any other information that is likely to assist the Examiner, especially if this cannot be discovered in the scripts;
- (e) any help given to a candidate.

*The Supervisor is asked to supply the following information:*

Plan of work benches, giving details by candidate numbers of the places occupied by the candidates for each session and a copy of the 'Supervisor's Results'.

NAME OF CENTRE .....

SIGNED .....

*Supervisor*

CENTRE NUMBER .....

DECLARATION (to be signed by the Principal)

The preparation of this practical examination has been carried out so as to maintain fully the security of the examination.

NAME .....

(in block capitals)

SIGNED ..... (Principal)



Permission to reproduce items where third-party owned material protected by copyright is included has been sought and cleared where possible. Every reasonable effort has been made by the publisher (UCLES) to trace copyright holders, but if any items requiring clearance have unwittingly been included, the publisher will be pleased to make amends at the earliest possible opportunity.

To avoid the issue of disclosure of answer-related information to candidates, all copyright acknowledgements are reproduced online in the Cambridge International Examinations Copyright Acknowledgements Booklet. This is produced for each series of examinations and is freely available to download at [www.cie.org.uk](http://www.cie.org.uk) after the live examination series.

Cambridge International Examinations is part of the Cambridge Assessment Group. Cambridge Assessment is the brand name of University of Cambridge Local Examinations Syndicate (UCLES), which is itself a department of the University of Cambridge.